

# DCS Series Brushed DC Servo Drives



## Features:

- \*Advanced DSP control technology for smooth motion
- \*18 VDC to 80 VDC supply range and capable of providing 10 A continuous and 20 A peak current
- \*Suitable for 10 W to 400 W brushed DC servo motors
- \*Position control with 4 × encoder resolution accuracy
- \*Adjustable position following error alarm range
- \*Electronic gearing with adjustable ratio from 1/255 to 255
- \*Built-in motion controller for self-test with trapezoidal velocity profile
- \*Pulse and direction (PUL/DIR) inputs can alternatively be configured as clockwise and counter-clockwise pulse inputs (CW/CCW)
- \*Opto-isolated inputs supporting single-ended or differential signals
- \*PC-based and handheld configuration tools available
- \*Over-current, over-voltage, under-voltage, phase error, encoder error and position following error protections
- \*10 error history log

## Power Specifications

Model	Input Voltage (VDC)	Continuous Current (A)	Peak Current (A)	Power (W)
DCS303	18 to 30	3	15	90 Max
DCS810	18 to 80	10	20	400 Max
DCS810S	18 to 80	10	20	400 Max
DCS811	18 to 80	11	20	400 Max

## Introduction

The DCS series drives are fully digital brushed servo drives developed with high speed DSP and advanced algorithms for smooth motion control. Opto-isolated pulse and direction control inputs allow the drives to be drop-in replacements for stepping motor drives. In low power motion control applications DC servo motor systems perform as well as or better than AC servo motor systems with high precision, high stability and low noise at far lower costs.

The DCS series drives are very easy to use. Leadshine supplies PC-based ProTuner software for Windows. A handheld tuning and configuration tool, the STU-DCS allows configuration of the drives out in the field.

The DCS303 is a micro-size (86 × 55.5 × 20.5 mm or 3.4 × 2.2 × 0.81 inches) brushed DC servo drive. It is ideal for low power applications with limited mounting space.

The DCS810S is designed to replace the DB810-50V which was widely used in inkjet printers. It offers improved performance with the same electrical connections.

The DCS810 has differential command and encoder feedback inputs and offers better anti-interference performance.

The DCS811 features high speed response and full closed-loop control. It can drive a brushed DC motor without an encoder and use feedback signals from an encoder or linear scale attached directly to the load. Electronic damping and fast torque control technology allow the DCS811 to provide fast response with good vibration suppression. The drive is particularly suited to applications requiring high precision positioning and low cost.



## Performance Specifications (with DCM Series Servo Motors)

- \* Position following error: adjustable down to  $\pm 1$  count
- \* Maximum acceleration (No Load): 80 RPM / ms
- \* Maximum speed: 3500 RPM
- \* Positioning accuracy:  $\pm 1$  count
- \* Velocity accuracy:  $\pm 2$  RPM
- \* Input frequency: up to 250 kHz (500 kHz for the DCS811)
- \* Low speed control: down to 1 RPM
- \* Suitable for 18 VDC to 80 VDC brushed DC servo motors

## Applications

Widely used in large format inkjet printers, solvent printers, small and medium engraving machines, electronic manufacturing, NC machines, packing machines and production line equipment. These brushed DC servo drives are particularly suited to systems that require high precision and high speed at low cost.

## Part Number

DCS ┆	8 ┆	10 ┆	S ┆
Brush DC Servo Drive	Maximum Input Voltage 8: 80 VDC 3: 30 VDC	Continuous Current 10: 10 A 3: 3 A	Special Model Symbol Blank: Standard S: Single-ended input

## General Specifications

### Electrical Specifications

Parameters	DCS303	DCS810	DCS810S	DCS811
Input Voltage	18 to 30 VDC	18 to 80 VDC	18 to 80 VDC	18 to 80 VDC
Continuous Current	3 A	10 A	10 A	10 A
Peak Current	15 A	20 A	20 A	20 A
Pulse Input Frequency		250 kHz		>500 kHz
Logical Signal Input Current		7 to 20 mA		
Current Provided for Encoder		50 mA		
Isolation Resistance		500 M $\Omega$		

### Command and IO Signals

Parameters	DCS303	DCS810	DCS810S	DCS811
Operation Mode	Position			
Input Command	PUL/DIR Single-ended	PUL/DIR & CW/CCW Single-ended & Differential	PUL/DIR & CW/CCW Single-ended	PUL/DIR & CW/CCW Single-ended & Differential
Motor Encoder	A, B phase Single-ended	A, B phase differential	A, B phase single	None
External Encoder	None	None	None	A, B phase differential
Enable Signal	Single-ended	Differential	Differential	Differential
Alarm Signal	OC output, optical isolated	None	OC output, none-isolated	None
Communication Connector	B4B-PH	RJ-11	RJ-11	RJ-11
Communication Interface	RS232			
Protection Function	Over voltage, Under voltage, Over current, Phase error, Position following error limit, Encoder failure			
Matching Motors	18 to 30 VDC brush DC servo motors with single-ended encoder, power up to 90W	18 to 80 VDC brush DC servo motors with differential encoder, power up to 400W	18 to 80 VDC brush DC servo motors with single-ended encoder, power up to 400W	18 to 80 VDC brush DC servo motors without encoder, power up to 400W

### Configuration & Tuning Tools

Parts	DCS303	DCS810	DCS810S	DCS811
PC Based Software	ProTuner	ProTuner	ProTuner	ProTuner
Handheld Servo Tuning Unit	STU-DCS	STU-DCS	STU-DCS	STU-DCS

### Mechanical Specifications

Parameters	DCS303	DCS810	DCS810S	DCS811
Size (H x W x D) (mm)	86 x 55.5 x 20.5	116 x 69.2 x 26.5	116 x 69.2 x 26.5	116 x 69.2 x 26.5
Weight (g)	100	210	212	220

ACS & ACM
ACS806
ACS806
ACS806
ACM Series
BLM Series
DCS Series
DCS303
DCS810
DCS810S
DCM Series

**Operating Environment and Other Parameters**

Model	DCS303	DCS810	DCS810S	DCS811
Cooling	Natural cooling or forced cooling			
Environment	Avoid dust, oil fog and corrosive gases			
Ambient Temperature	0 °C to 50 °C (32 °F to 122 °F)			
Humidity	40% to 90% RH			
Vibration	5.9 m/s <sup>2</sup> Max			
Storage Temperature	-20 °C to +65 °C (-4 °F to 149 °F)			

**Tips**

(a) Although both regulated and unregulated power supplies can be used to power the drives, unregulated power supplies are preferred due to their ability to withstand current surge. Select a power supply with output voltage equal/approach to rated voltage of the chosen motor. An external electrolytic capacitor (rated voltage > 1.3 times of the voltage of power supply) should be added between power input terminals if voltage ripples is larger than 5% of power supply rated voltage. Rated power of the power supply should be larger than 1.2 times of the power of the servo motor. The larger the power of the power supply, the better, especially in applications requiring quick acceleration.

(b) Drive's working temperature should be lower than 70°C (or 158°F), and motor working temperature should be lower than 80 °C (or 176 °F). Use forced cooling to cool the system if necessary.

(c) To improve anti-interference performance of the system, use twisted pair shield cable for control signals and correctly ground the system. To prevent noise coupled on pulse/direction signal, pulse/direction signal wires, motors and power wires should not be tied up together. Separate them by at least 10 centimeters (4 inches) to avoid disturbing signals generated by motor, which will easily disturb pulse and direction signals, causing motor position error, system instability and other failures.

(d) Don't pull and plug motor & power wires while a drive is powered ON, is high current flowing through motor coils (even stopped). Pulling or plugging motor or power wires with power on will cause extremely high voltage surge, which could damage the drive.

(e) If a power supply serves several drives, connecting those drives separately is recommended instead of daisy-chaining connection.

(f) In order to avoid some fault operations and deviations, PUL, DIR and ENA signals should abide by some rules, shown as following diagrams:

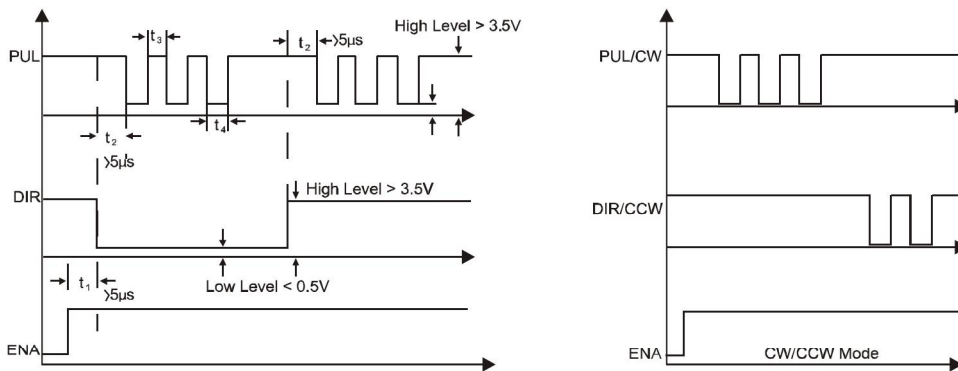

**Notes:**

- (1) t1: ENA must be ahead of DIR by at least 5 µ s. Usually, ENA+ and ENA- are NC (not connected).
- (2) t2: DIR must be ahead of PUL active edge by at least 5 µ s to ensure correct direction.
- (3) t3: High Level not less than 2 µ s (DCS303, DCS810, DCS810S) or 1.0 µ s (DCS811).
- (4) t4: Low Level not less than 2 µ s (DCS303, DCS810, DCS810S) or 1.0 µ s (DCS811).

**PC Based and Handheld Configuration and Tuning Tools**

Leadshine offers PC based and handheld configuration and tuning tools to meet different requirements and configuration and tuning environments. The user can tune the DCS series drives with two different tuning tools, including Pro Tuner (Windows based setup software) and STU-DCS (Handheld servo tuning unit).

**Pro Tuner (Windows based setup software)**



**STU-DCS (Handheld servo tuning unit)**



**Leadshine DC Servos**

- ACS & ACH
- ACS806
- ACS806
- ACS806
- ACM Series
- BLM Series
- DCS Series
- DCS303
- DCS810
- DCS810S
- DCM Series

### ProTuner (Windows Based Setup Software)

- Upload and Download parameter settings
- Digital oscilloscope for real-time current, velocity, position following error display. Measurements can be taken using the mouse pointer.
- PID parameter settings for position loop
- PI parameter settings for current loop
- Electronic gear rate setting from 1/255 to 255
- Position following error range setting
- Encoder resolution setting
- Parameter settings for self motion test (with trapezoidal velocity profile)
- Read the latest 10 failure events and clear the events

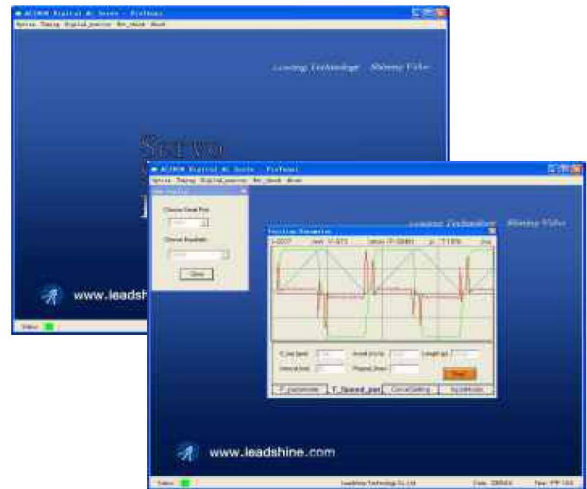

\* 1 PC RS232 interface is necessary  
 \*\* Leadshine offers a cable for interfacing the drive to an RS232 port on the computer. USB-to-RS232 converter also available.

### STU-DCS (Handheld Small Servo Tuning Unit)

- Similar to most HMI of servo drives from other manufacturers
- PID parameter settings for position loop
- Electronic gear rate setting from 1/255 to 255
- Position following error range setting
- Real-time current, velocity, position following error display.
- Parameter settings for self motion test (with trapezoidal velocity profile)
- Read the latest 10 failure events and clear the events

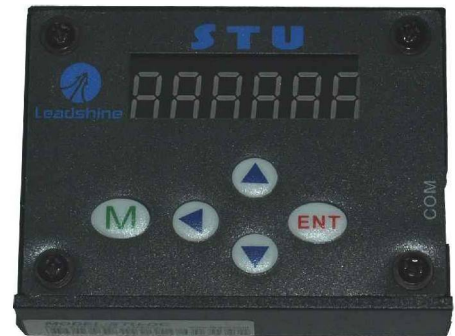

\* Leadshine offers a special cable for communication between the drive and the STU-DCS handheld tuner.

### Order Information

Part	Model	Description
DC Servo Drives	DCS303	Micro-size digital servo drive for 5-90W brush DC servo motors, input: 18-30 VDC, Cont. Cur: 3A, Peak Cur: 15A
	DCS810	Differential digital servo drive for 20-400W brush DC servo motors, input: 18-80 VDC, Cont. Cur: 10A, Peak Cur: 20A
	DCS810S	Single-ended digital servo drive for 20-400W brush DC servo motors, input: 18-80 VDC, Cont. Cur: 10A, Peak Cur: 20A
	DCS811	Full closed-loop digital servo drive for 20-400W brush DC servo motors, input: 18-80 VDC, Cont. Cur: 10A, Peak Cur: 20A
Tuning Tools	ProTunner	PC based configuration & tuning software (free).
	STU-DCS	Handheld configuration & tuning unit. Each customer can get one STU-DCS for free.
	USB Cable	USB cable for connection & communication between the servo drive and PC USB interface.
	R232 Cable	RS232 cable for connection & communication between the servo drive and PC RS232 interface.
DCM Series Motors	DCM50xxx-1000	Screw mounted brush DC servo motor with a 1000 line incremental encoder (A, B phase single-ended).
	DCM50xxx-500	Screw mounted brush DC servo motor with a 500 line incremental encoder (A, B phase single-ended).
	DCM50xxxD-1000	Screw mounted brush DC servo motor with a 1000 line incremental encoder (A, B phase differential).
	DCM50xxxD-500	Screw mounted brush DC servo motor with a 500 line incremental encoder (A, B phase differential).
	DCM57xxx-1000	Flange mounted brush DC servo motor with a 1000 line incremental encoder (A, B phase single-ended).
	DCM57xxx-500	Flange mounted brush DC servo motor with a 500 line incremental encoder (A, B phase single-ended).
	DCM57xxxD-1000	Flange mounted brush DC servo motor with a 1000 line incremental encoder (A, B phase differential).
DCM57xxxD-500	Flange mounted brush DC servo motor with a 500 line incremental encoder (A, B phase differential).	

ACS & ACM
ACS006
ACS006
ACS006
ACM Series
BLM Series
DCS Series
DCS303
DCS810
DCS810S
DCM Series